

# PadPuls M1

Art. no.: IM001 + IM001G

(Valid from M-Bus generation: \$07)

Article no. IM001: 1-channel pulse collector (OEM board)  
 Article no. IM001G: 1-channel pulse collector with case for wall-mounting

## Contents

1 Functional description.....	2
2 Installation and startup .....	3
2.1 Mounting the case.....	3
2.2 Opening the case.....	3
2.3 Connecting.....	3
3 Parameterization using MBCONF .....	5
3.1 Installation.....	5
3.2 Operation .....	5
3.3 Sheet Info.....	6
3.3 Sheet PadPuls M1 .....	9
4 M-Bus Telegrams .....	12
5 Technical data .....	14

## 1 Functional description

The PadPuls M1 serves for the adaptation to the M-bus system of consumption measuring instruments, such as, current, gas or water meters. However, the meters to be adapted must have a floating pulse output. The user can configure the PadPuls M1 with the MBCOPNF program so that the scanned impulses are converted to units such as kWh, m<sup>3</sup>, J and so on. The configuration is very easy with the MBCONF user interface.

When connected to the M-bus the PadPuls M1 is powered from the bus. A built-in battery ensures that metering continues even if the M-Bus fails for longer than the normal calibration time for the water meter or heat counter. The battery also ensures that the meter readings and the configuration data is maintained in RAM. The battery jumper should therefore be plugged in at all times. The jumper serves only to disconnect the battery from the circuitry should the battery need to be replaced.

Device data can be protected against unauthorized configuration. The PadPuls M1 can be switched to protection mode with a special M-Bus telegram. Subsequent changes to device parameters cannot be made in this operating mode. The protection mode can then only be disabled by opening the sealable housing and pressing the unprotect pushbutton.



## 2 Installation and startup

### 2.1 Mounting the case

The housing is fixed to the wall with two screws, which are screwed diagonally through the holes marked with "wall". The heads of the screws should be maximum 6 mm in diameter so that the cover is not screwed as well.

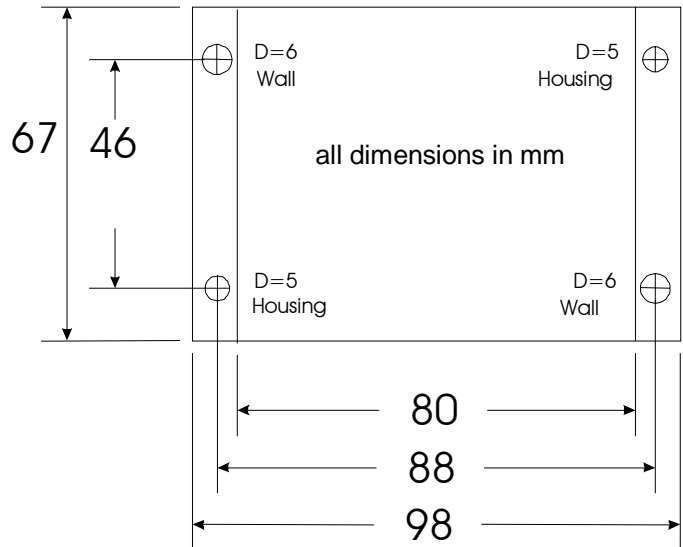

### 2.2 Opening the case

To deactivate the write protection the housing cover can be opened by removing the metal screws above at the left and below at the right. The unprotect pushbutton is then accessible from outside; the unit is unprotected by pressing this button. Use a suitable adhesive seal to prevent the housing from being opened unnoticed.

### 2.3 Connecting

The following picture shows a typical installation including the PadPuls M1:

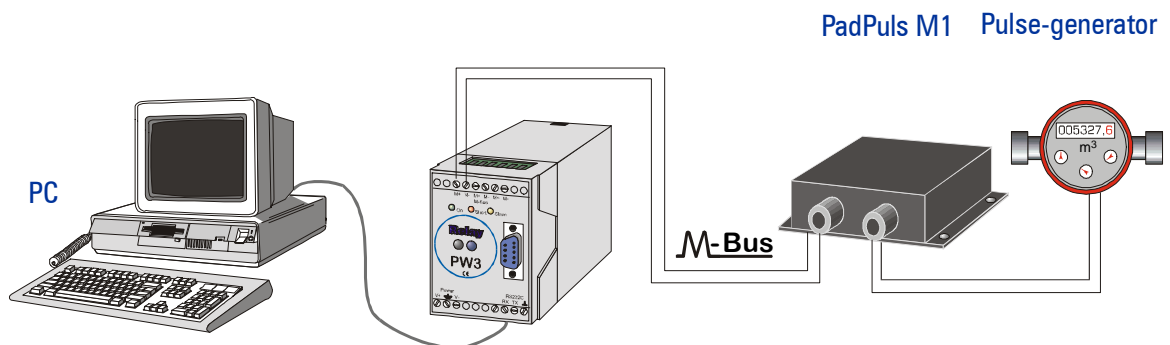

After opening the housing please lead the M-Bus cable through the left cable gland of the cover and connect the cable to the left terminal. Then do the same with the cable of the pulse generator (right side). Please connect an optional shielding to the terminal labeled with „Schirm“. Connect the shielding only at the PadPuls.

- Impulse devices with floating contacts (reed contacts) are connected to the terminals marked with “pulse” using any polarity. If cable shielding is available, it can be wired **single-sided** to the terminal marked with “shield”.
- Impulse devices with optocouplers or electrically isolated transistor outputs must be connected to the “pulse” with the correct polarity. The left-hand terminal is the positive connection and the middle terminal the negative connection.

The following graphic shows the position of the terminals and the button:

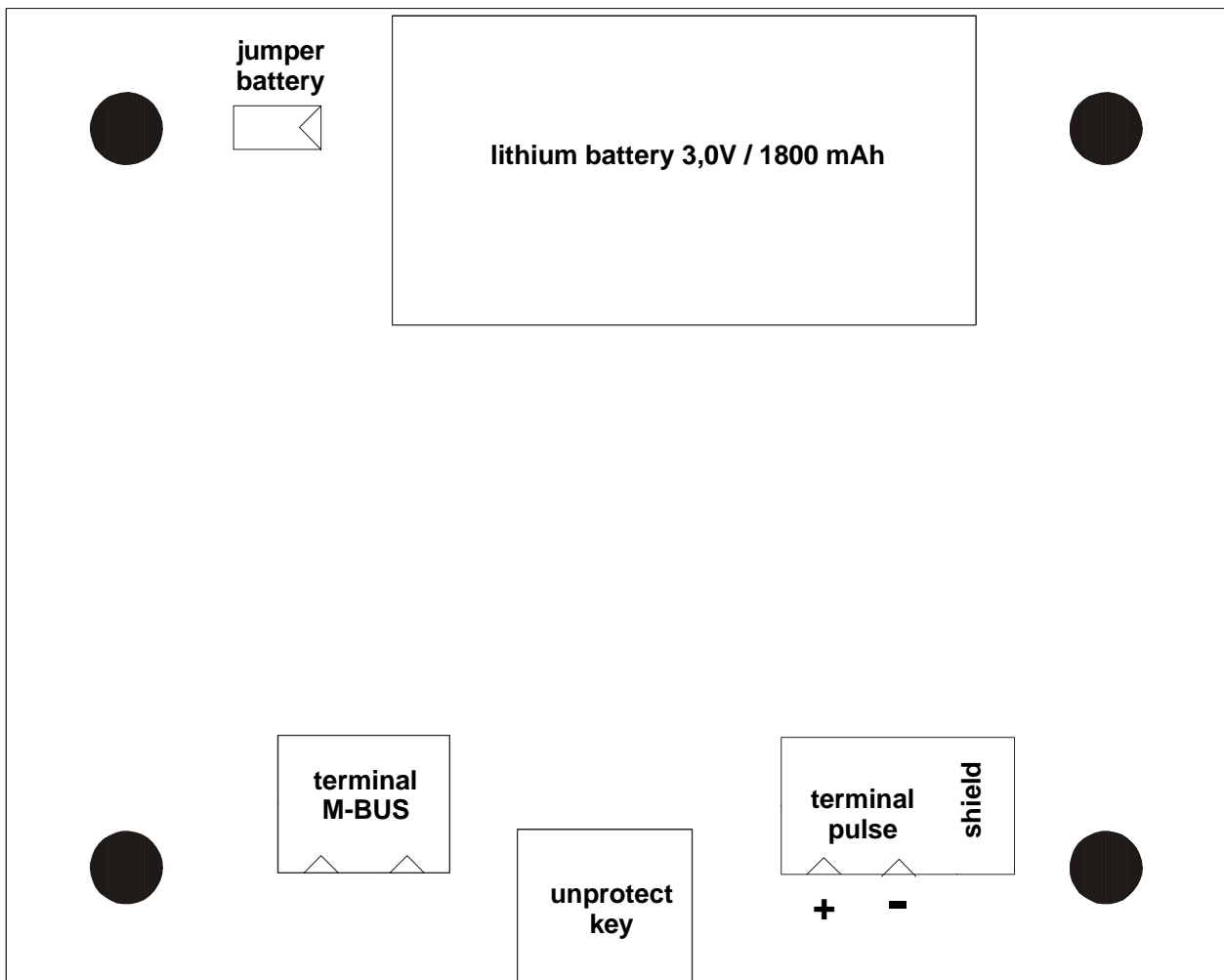

## 3 Parameterization using MBCONF

The configuration of the device must be adapted by the customer to the respective installation. We include the software MBCONF with delivery. You can get the old software PADCON for MS DOS or MS Windows 3.1 systems from our web page [www.relay.de](http://www.relay.de).

### 3.1 Installation

The software MBCONF for configuration of the pulse adaptor is a 32-bit application, which can be executed on IBM-PC compatible computers under the operating systems Windows 95 / 98 / NT 4.0. The desktop PC or laptop must have a free serial RS232C interface to connect the M-Bus level converter. The PadPuls M1 to be parameterized must be connected directly (i.e. as only M-Bus device) to the M-Bus output of the level converter.

Please start the file "MBCONF\_SETUP.EXE" from Windows Explorer or via "Start – Execute" to install the software from version 1.40 up. Subsequently you select the language of the installation procedure. The setup software can create a program group and a link on the desktop on demand. You can then execute both versions for German and English language either from start menu or desktop.

### 3.2 Operation

After program start the user operates the software according to the Windows conventions with the mouse or the keyboard. If you stay with the mouse on a button or an input field, then a hint to its function appears. Light-grey fields and boxes are not capable for editing.

All input fields and buttons have an underlined letter. The function can be activated by simultaneous pressing of the keys [ALT] and the respective letter. Within dialogs the cursor can be moved with the keys [TAB] or [SHIFT][TAB ] forwards and back. [SPACE ] activates or deactivates selection boxes. Multiple selection boxes (arrow at the right edge) can be activated with [↓]. The user then selects an entry with [↓] and [↑]. By pressing [RETURN] the selected entry is taken over. With [ESC] the selection box is left without transfer.

The program is arranged as a sheet system. The sheet "Info" contains general options of the communication with the M-Bus device to be configured. In this sheet the user can select the serial port of the PC, the baudrate of the PC, the baudrate of the M-Bus device and the M-Bus primary address which is used for communication. After a successful connection with the M-Bus device, further manufacturer information is shown in the sheet "Info" and additional device-specific sheets are displayed.

### 3.3 Sheet Info

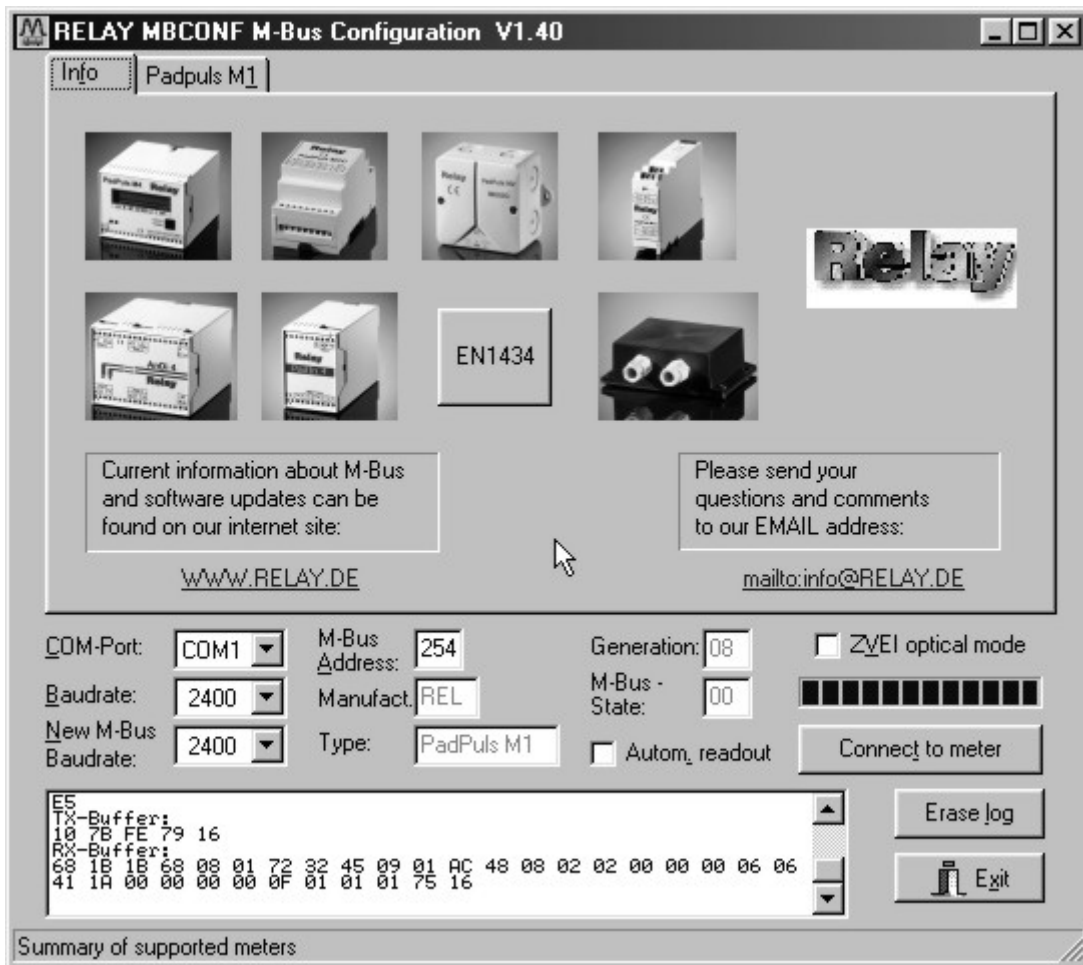

This sheet shows some photos of supported M-Bus devices from the product range of the Relay GmbH, the PadMess GmbH and further manufacturer. Here are also links to the Internet page, from which the current version of the program can be downloaded, and to the email address for criticism and suggestions to the program.

The lower third of this card is likewise visible in every other card. Here the following input fields and buttons are always attainable:

#### **COM-Port**

is the serial port of the PC to which the M-Bus level converter is connected. The selected port will be saved in an INI file and will be restored on startup. Therefore the COM-Port has to be configured only once.

#### **Baudrate**

ist the transmission speed of the serial port of the PC used for parameterization. Possible selections for this used M-Bus baudrate are 300, 2400 or 9600 baud. Attention: Baudrates of more than 2400 baud are not supported by all M-Bus level converters which are available on the market! The selected baudrate must be

identical to the baudrate of the M-Bus device. (see: “New M-Bus Baudrate”). The PadPuls M1 supports the baudrates 300, 2400 and 9600Bd.

**New M-Bus Baudrate**

allows reprogramming the baudrate of the M-Bus device. The new baudrate is sent to the M-Bus device after a change in the appropriate selection box. If the M-Bus slave accepts this command, it acknowledges the telegram with the single character „\$E5“ (\$ for hexadecimal notation) using the old baudrate. Afterwards the device switches to the new baudrate. This button is not needed for the PadPuls M1, since it automatically detects the baudrate used by the master.

**M-Bus Address**

is the primary address of the connected M-Bus slave. In a direct connection with only one slave you can use the broadcast address 254. Using this address every M-Bus device must answer regardless of its own address.

**Connect to meter**

is used to request data from the slave. The type of device is then automatically recognized. The items “Manufact.”, “Generation”, “Type” and “M-Bus State” will then be refreshed. New sheets are generated depending on manufacturer and type of the M-Bus device. In case of PadPuls M1 a sheet labelled with “PadPuls M1” appears.

**Manufact.**

is an item that shows the 3-letter manufacturer code after successful reading (“Connect to meter”). The item is read only.

**Generation**

shows the software revision of the firmware of the connected M-Bus device. The item is read only.

**Type**

shows the type (here: PadPuls M1) of the connected device. This item is read only.

**M-Bus State**

shows the M-Bus state of the connected device. This item is read only.

**ZVEI optical mode**

If this option is activated, devices with an optical interface and protocol according to EN 1434-3 can be read and programmed using an optical reading head (e.g. PadPuls M4 / M4L).

**Autom. readout**

The software always reads the data after writing, if this option is activated (useful for checking the correct programming).

### **Log-Window**

The so-called log window is always visible. All M-Bus communication steps are logged in this window. Data is displayed in hexadecimal notation. It is possible to mark outputs in the log window and copy them with the keys "CTL-C" to the windows clipboard. Then the data can be easily imported to any text editor for documentation. As soon as the max. storage capacity of the window is achieved, no more data is logged. If you want to log further, you must delete the logged data.

The following buttons are also always visible:

**Erase log**                clears all outputs inside the log window.

**Exit**                        terminates the program and stores the current setting of serial port (port no.) into the INI file.



### 3.3 Sheet PadPuls M1

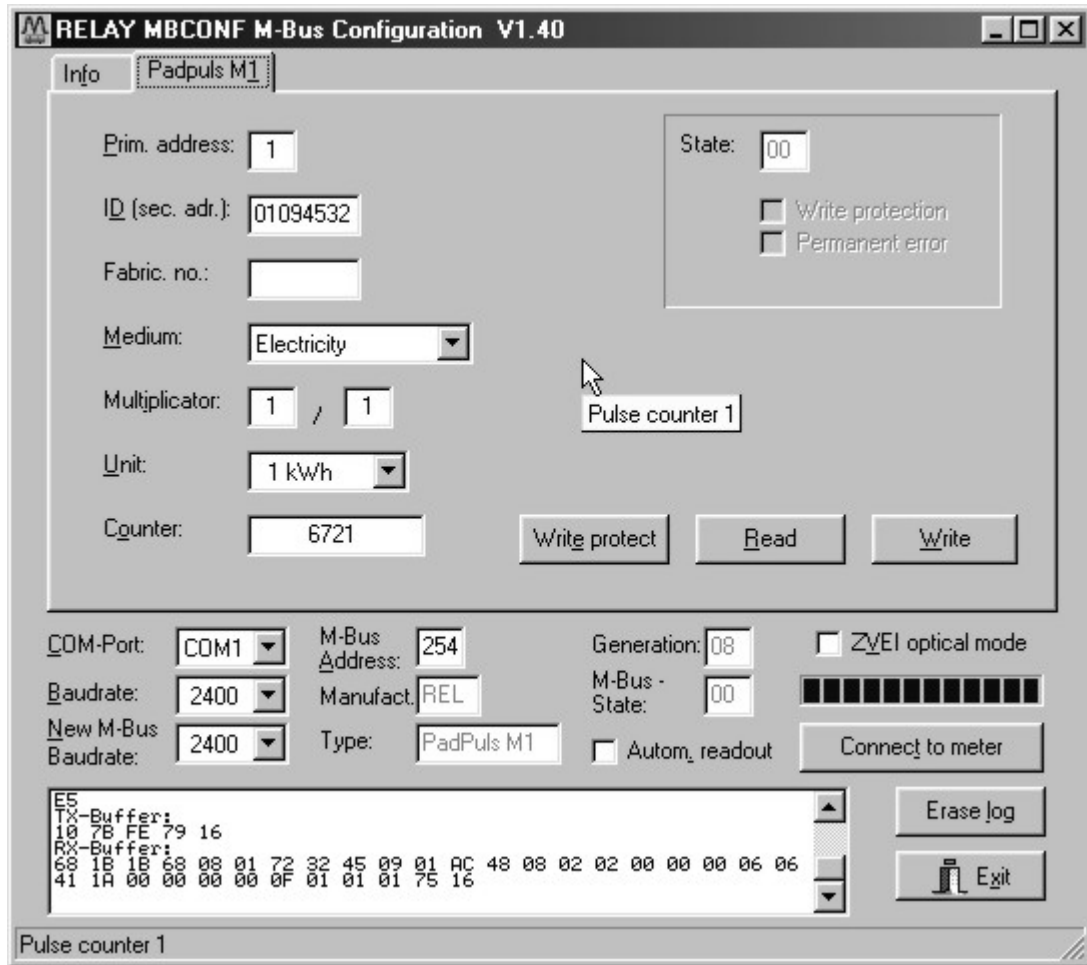

These sheet shows the actual settings and values of the PadPuls M1. The following input boxes and buttons are used to change the params of the pulse adapter:

**Primary address** is the M-Bus address of the device. Values between 1 and 250 can be entered in this field for new assignment of the address. After pressing the “Write” button the software programs this primary address and further variable settings on this sheet into the M-Bus device.

**ID (sec. adr.)** is the 8 digit M-Bus ID (identification no.), which is also used for secondary addressing of this adapter.

**Fabric. no.** is insignificant for PadPuls M1.

**Medium** describes the measured medium of the connected meter. Examples: Oil, Water, Heat, Electricity

<b>Multiplicator</b>	is the pulse increment (multiplier) of the connected meter. For each registered pulse the device adds “multiplier” to the counter. The numerator can take values between 0 (no counting) and 255, the denominator between 1 and 255.
<b><u>Unit</u></b>	is the physical unit of the counter and of the pulse increment. All proper units including variants with power of ten from the DIN EN 1434-3 are offered in the selection list.
<b><u>Counter</u></b>	is the accumulated counter. It has to be related to the unit mentioned above. The counter can be programmed equal to the counter of the connected meter in a range of 0 to 0 to $1 \times 10^{12}$ or in detail 1.099.511.627.775 (= 00 FF FF FF FF FF hex.).
<b>State</b>	is the M-Bus state in hexadecimal notation.
<b>Write protection</b>	is marked, if the device is protected against programming. Then you cannot configure the adapter. The protection can be removed after opening the sealable front cover of the housing and pressing the “Unprotect” pushbutton.
<b>Permanent error</b>	is insignificant for the PadPuls M1.
<b><u>Write protect</u></b>	Transmits a command to the PadPuls M1 to activate write protection. The PadPuls then allows no further configuration. It is protected against unnoticed manipulation.
<b><u>Read</u></b>	reads the M-Bus device and refreshes the data on the selected sheet.
<b><u>Write</u></b>	sends the current options to the pulse converter, which stores this data into the battery buffered memory. The PadPuls M1 changes the options only if the write protect is deactivated. It is recommended to read the data after writing and check it.

## Notes:

1. Please press first the button „Connect to meter“ after connecting a new M-Bus device. Afterwards all sheets are refreshed.
1. Examples for configuration of pulse increment and unit:
  - Water meter with counter = 45120 l and 1 Pulse = 10 l:  
Choice 1: Unit = 10 l, Multiplier = 1 / 1, Counter = 4512 ( x 10 l)  
Choice 2: Unit = 1 l, Multiplier = 10 / 1, Counter = 45120 ( x 1 l)
  - Electricity meter with counter = 78346 kWh and 64 pulses / kWh:  
Choice: Unit = 1kWh, Multiplier = 1 / 64, Counter = 78346 ( x 1kWh)
  - Electricity meter with counter = 112,345 kWh and 1000 pulses / kWh:  
Choice: Unit = 1Wh, Multiplier = 1 / 1, Counter = 1123454 ( x 0,001Wh)

## 4 M-Bus Telegrams

### 1) General

- Communications according to EN1434-3
- Transmission rates 300, 2400 and 9600 Bd with auto-baud detect
- Primary and secondary addressing with wild cards
- SND\_NKE / E5, SND\_UD / E5, REQ\_UD2 / RSP\_UD is supported

### 2) Definitions

- All values are specified in hexadecimal
- Empty fields in the “Contents” line are variable
- Index 1 designates the least-significant byte in fields containing several bytes

### 3) RSP\_UD Telegram

Byte	1	2	3	4	5	6	7	8	9	10	11	12	13
Name	Start	Length	Length	Start	C	A	CI	ID1	ID2	ID3	ID4	MAN1	MAN2
Inhalt	68	1B	1B	68	08		72					AC	48

Byte	14	15	16	17	18	19	20	21	22	23	24	25	26
Name	GEN	MED	TC	Status	SIG1	SIG2	DIF	VIF	Count1	Count2	Count3	Count4	Count5
Inhalt				00 / 80	00	00	06						

Byte	27	28	29	30	31	32	33
Name	Count6	Spez.	Index	Numerator	Denominator	CS	Stop
Variable	00	0F	01				16

### Notes:

- Manufacturer MAN = “REL” (48AC)
- Generation GEN ( at this time \$08, reserved range from \$01 to \$0F)
- Status bit 7 (MSB):
  - 1 → write protection set
  - 0 → write protection removed
- VIF: Set by the user; VIF = unit with decimal power (MSB not set)
- Count: Meter reading (most-significant byte = Count6 always zero)
- Numerator / Denominator: Impulse value (increment in multiples of the VIF per impulse):

$$1 \text{ Pulse} = \frac{\text{Numerator}}{\text{Denominator}} \cdot \text{VIF}$$

## 4) Configuration Telegram

Byte	1	2	3	4	5	6	7	8	9	10	11	12	13
Name	Start	Length	Length	Start	C	A	CI	DIF1	VIF1	PAdr	DIF2	VIF2	ID1
Inhalt	68	1C	1C	68	53		51	01	7A		07	79	

Byte	14	15	16	17	18	19	20	21	22	23	24	25	26
Name	ID2	ID3	ID4	MAN1	MAN2	GEN	MED	DIF3	VIF3	Count1	Count2	Count3	Count4
Inhalt								06					

Byte	27	28	29	30	31	32	33	34
Name	Count5	Count6	Spez.	Index	Numerator	Denominator	CS	Stop
Inhalt		00	0F	01				16

### Notes:

- Variables to be configured can only be changed when no write protection is set
- Grey fields can be altered:
  - PAdr = Address (range 0–250)
  - ID = ID number (BCD)
  - MED = Medium
  - VIF3 = Unit and decimal power of the meter reading (MSB = 0)
  - Count = Pulse count (5 bytes binary, Count6 is always 00h)
  - Meter / denominator: impulse value (range 1–255 each)
- Miscellaneous fields (MAN and GEN are ignored)
- ID, MAN, GEN and MED are coded as in the fixed header of the variable data structure from EN1434-3
- The data block “Protect index denominator numerator” is specific to the manufacturer and is optional

## 4) Telegram to Set the Write Protection

Byte	1	2	3	4	5	6	7	8	9	10	11
Name	Start	Length	Length	Start	C	A	CI	Spez.	Protect	CS	Stop
Inhalt	68	05	05	68	53		51	0F	55		16

The write protection can only be reset by pressing the pushbutton on the circuit board.

## 5 Technical data

### Case:

ABS plastic, colour black

W x D x H: (100 x 88 x 35) mm

2 cable glands PG7, light-grey

Protective class IP 50

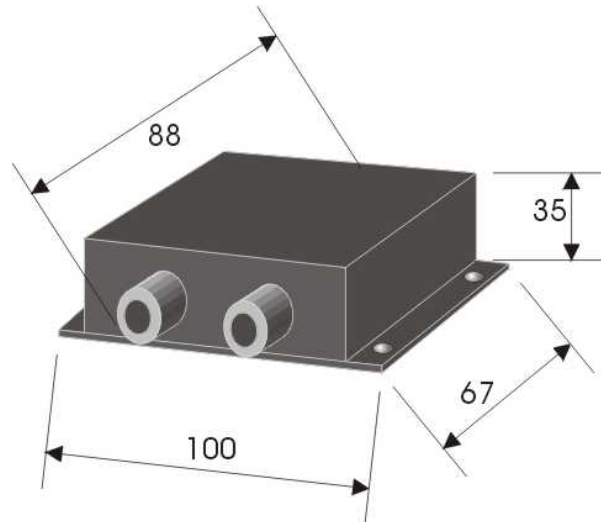

### CE marking:

The device is CE proofed.

### Environment:

Operating temperature 0°C .. 60°C

Storage temperature -25°C .. 60°C

Humidity (non condensing) 10% .. 70%

### Specifications for the pulse-generator-impulse contact

Potential	Floating, isolation to earth > 1MΩ
Resistance	Open > 10MΩ, closed < 10kΩ
Capacity (with cable)	< 2 nF
Minimum contact duration	5 ms
Minimum interval between 2 pulses	40 ms
Maximum pulse frequency	12,5 Hz with pulse length = pause length (1:1)

### PadPuls contact input

Contact voltage	2.5V to 3.4V
Contact current	2μA to 4μA
Guaranteed debounce time	1.2ms
Connection cable	Maximum 2 m twisted pair with shielding connected <b>only</b> on the PadPuls side

### Current consumption

Principle	Remote power supply from M-Bus with automatic changeover to battery backup upon bus failure
Battery	Lithium 3V, model 2/3AA, 1700mAh
Bus operation	max. 1.5mA (1 unit load), no battery loading



Notizen: